

AURA™ PRO UNDERGLOW

BLUETOOTH OPT7 GLOW APP & REMOTED CONTROLLED

RV CLASS B/B+ FIT

INSTALLATION GUIDE

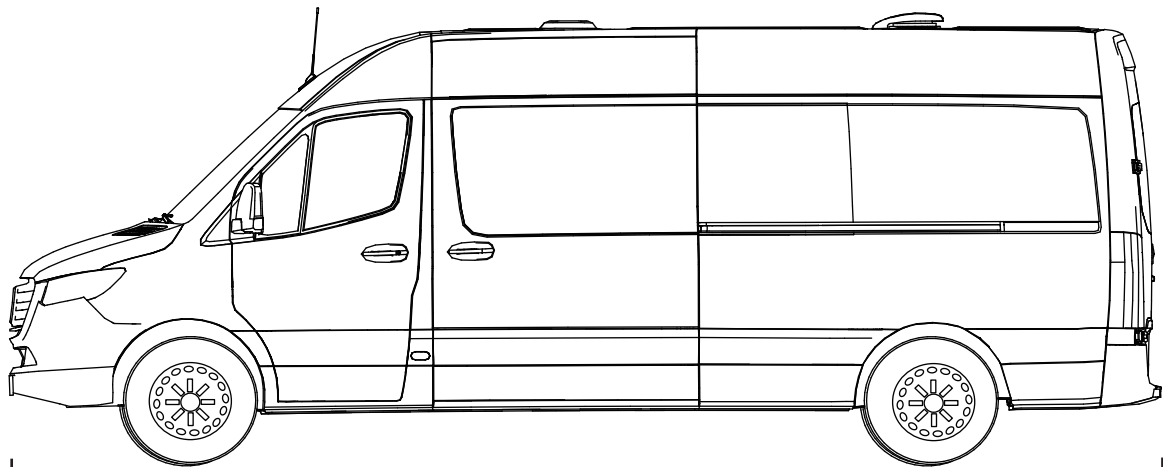

RV Class B : 19~23 ft
RV Class B+: 19~24 ft

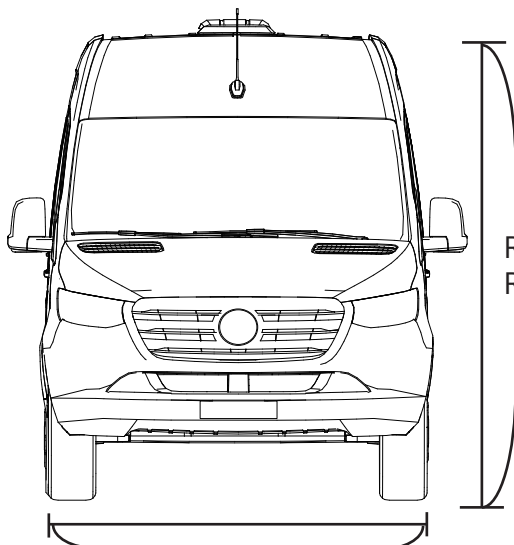

RV Class B : 10 ft
RV Class B+: 11 ft

RV Class B : 7 ft
RV Class B+: 8.1 ft

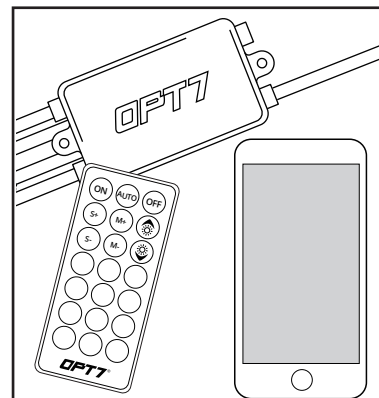

AURA PRO
BLUETOOTH CONTROL BOX

OPT7

COMPONENTS

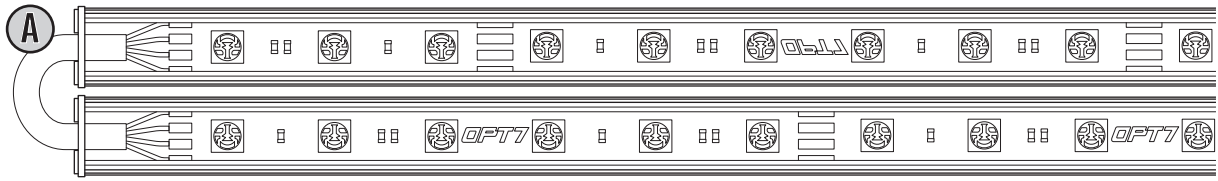

RIGID LIGHT BARS 2x48" (TWO-SECTION MOVABLE 24") + 8ft EXTENSION WIRE

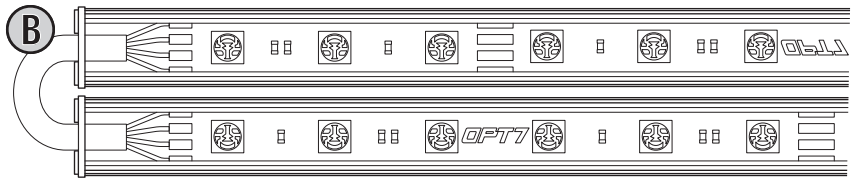

RIGID LIGHT BARS 1x36" (TWO-SECTION MOVABLE 18") + 8ft EXTENSION WIRE

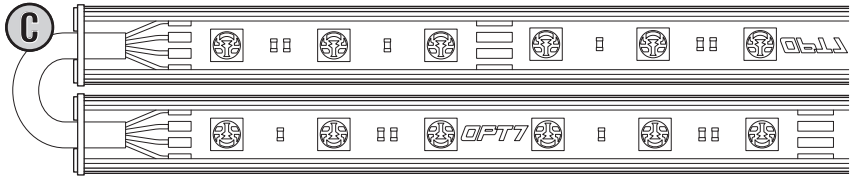

RIGID LIGHT BARS 3x36" (TWO-SECTION MOVABLE 18") + 18ft EXTENSION WIRE

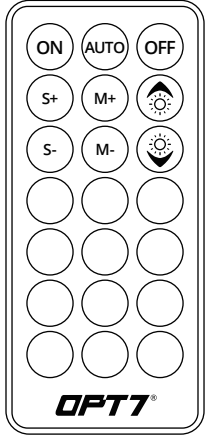

HAND HELD REMOTE

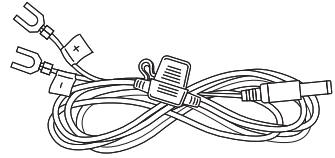
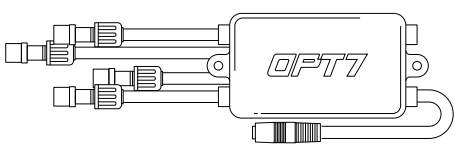

AURA PRO BLUETOOTH CONTROL BOX (SCAN QR CODE FOR APP USER GUIDE)

HARDWIRE POWER HARNESS

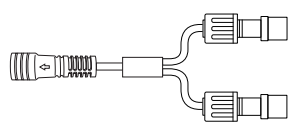

Y-SPLITTERS (WATERPROOF)

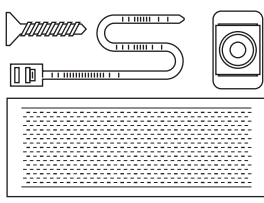

INCLUDES - WIRE MOUNTS, SELF-TAPPING SCREWS, BOOSTER, VELCRO, ZIP TIES

MOUNTING KIT

INSTALLATION

STEP 1

Inspect kit to ensure all contents were included.



STEP 2

Decide where to locate the control box and ensure wiring has enough length for light bars to be installed in desired location.

IMPORTANT

The control box is waterproof, but it should still be installed in a safe area of the vehicle. Please avoid installing it in the engine bay or on heated surfaces.

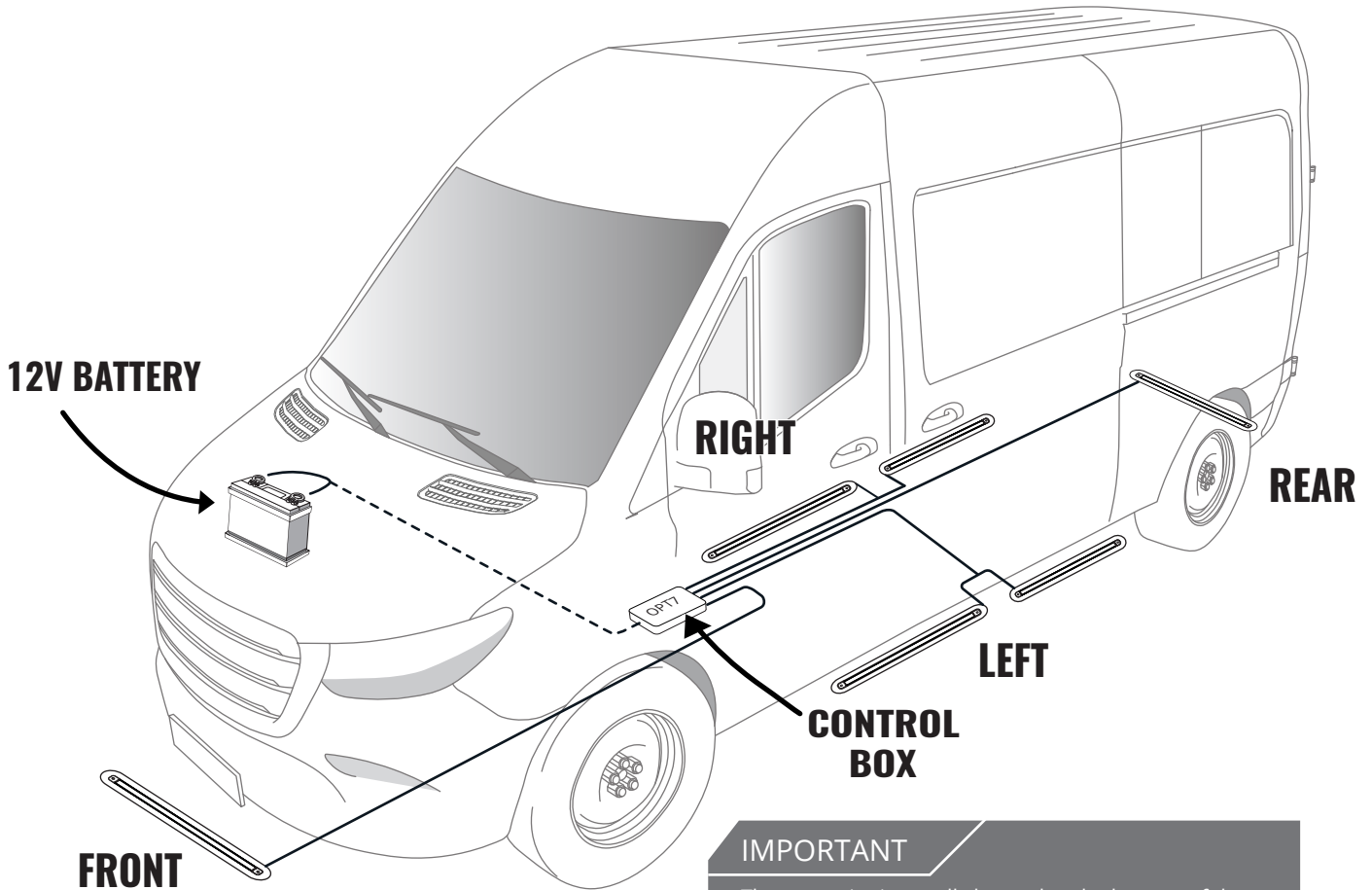

IMPORTANT

The spare tire is usually located at the bottom of the car. Please pay attention to the position of the spare tire of your vehicle after installing the rear light bar. Please find a suitable place to install the rear light bar to prevent the spare tire from being used normally.

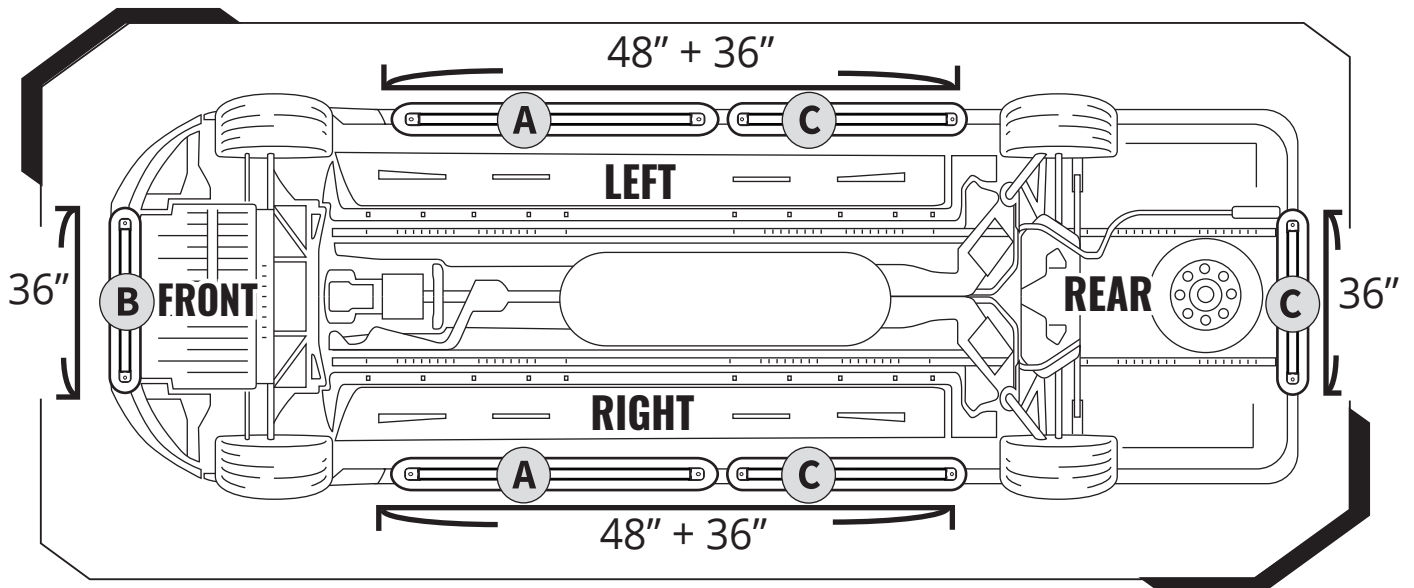

OPT7

EXAMPLES

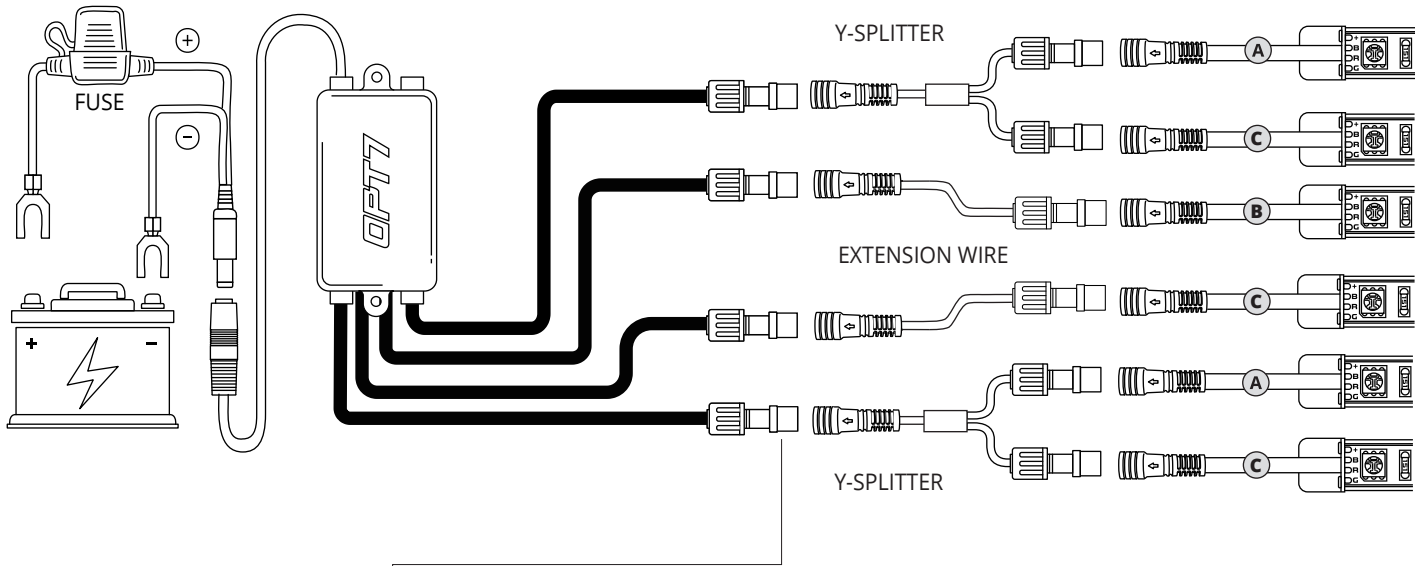

The extension wires are on the led bars.
Lay out the bars to measure the length prior to install for a successful installation.

- (B)** 1 x 36" (two-section movable 18") LED Bar + 8ft extension wire
- (A)** 1 x 48" (two-section movable 24") LED Bar + 8ft extension wire +
- (C)** 1 x 36" (two-section movable 18") LED Bar + 18ft extension wire
- (A)** 1 x 48" (two-section movable 24") LED Bar + 8ft extension wire +
- (C)** 1 x 36" (two-section movable 18") LED Bar + 18ft extension wire
- (C)** 1 x 36" (two-section movable 18") LED Bar + 18ft extension wire

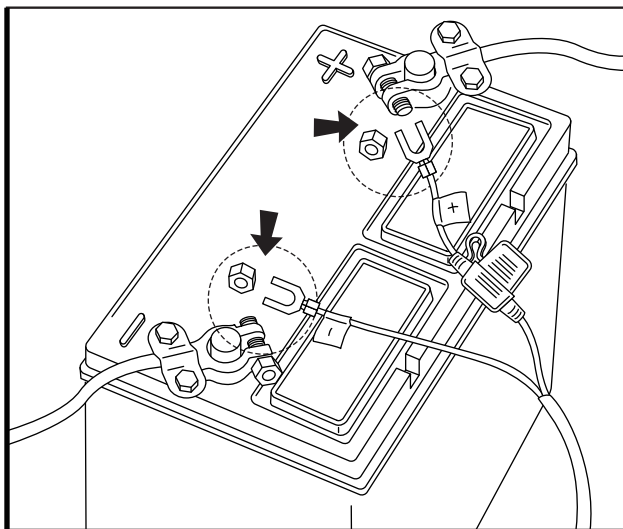

HOW TO CONNECT POWER HARNESS TO YOUR VEHICLE

- Connect the Red wire (+) of power harness to the vehicle battery's positive terminal.
- Connect the Black wire (-) of power harness to the vehicle battery's negative terminal or an unpainted area on your vehicle's frame.



WARNING

Please ensure the Underglow LED Bars / Control Box / Wirings are all mounted away from heated surfaces exceeding from 85°C or 185°F.

IMPORTANT

**BE SURE TO CONFIRM THE CORRECT DIRECTION OF THE ARROW!!
TO AVOID PRODUCT DAMAGE DUE TO INCORRECT INSTALLATION.**

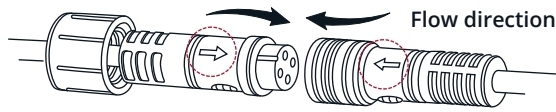

CORRECT INSTALLATION

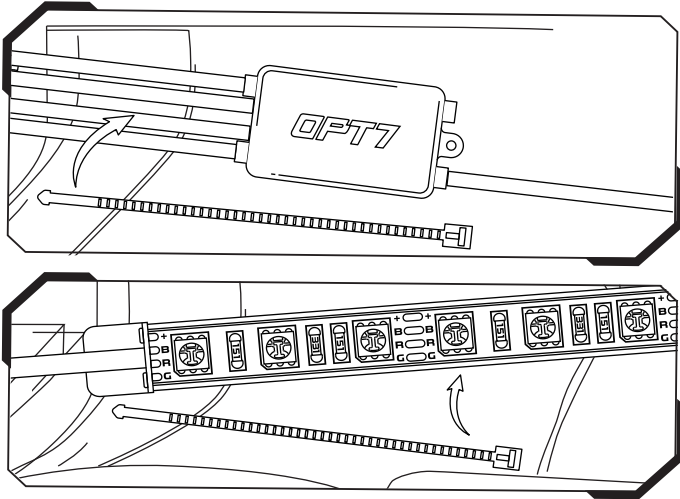

STEP 3

Secure Control box in desired location with Velcro or zipties.

*Ensure the control box is mounted away from water and heated metal surfaces for optimal performance.

STEP 4

Secure the light bars using the zip ties to tie all the wiring away from the moving components.

STEP 5

Using the included 21Key E-Z Remote, select your desired color or pattern.

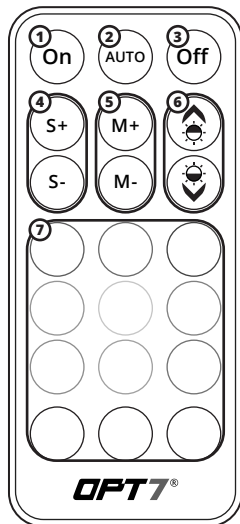

- | | |
|---|---------------------------|
| 1 | Power-ON |
| 2 | Automatic Color Change |
| 3 | Power-OFF |
| 4 | Speed +/- 10 Levels |
| 5 | Mode +/- 24 Modes |
| 6 | Dimmer 10 Levels |
| 7 | Color Selection 12 Colors |

NOTE: When you use this product, keep it within 10m/33ft as much as possible.

HOW TO PAIR THE REMOTE?

Pair the Device:

To pair the remote, reconnect the power, then aim the remote at the control box and hold the ON button until the LED strips flash white.

Unpair the Device:

To unpair the remote, reconnect the power, then aim the remote at the control box and hold the OFF button until the LED strips flash white.

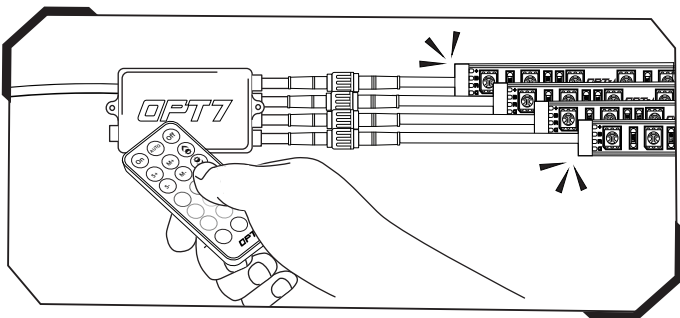

QR CODE TO DOWNLOAD



SCAN FOR APP
OPT7®
GLOW



Download the free "OPT7 GLOW" App
• Apple iOS (12+) available on App Store
• Android (8+) available on Google Play

STEP 6

Download the OPT7 GLOW to have the best experience.



Please scan to see the OPT7 GLOW user guide.

<https://wintis.ladesk.com/362302-OPT7-AURA-Glow-Application-User-Guide>

OPTION METHOD

To power the kit using an switched 10 AMP fuse tap method, you may purchase the AURA Universal Replacement Fuse Tap Adapter Set & Power Wire on our website. (*Not included; sold separately.)

Feel free to contact us using the link below for product inquires or installation support.

OPT7 SUPPORT TEAM: <https://www.opt-7.com/pages/customer-support>

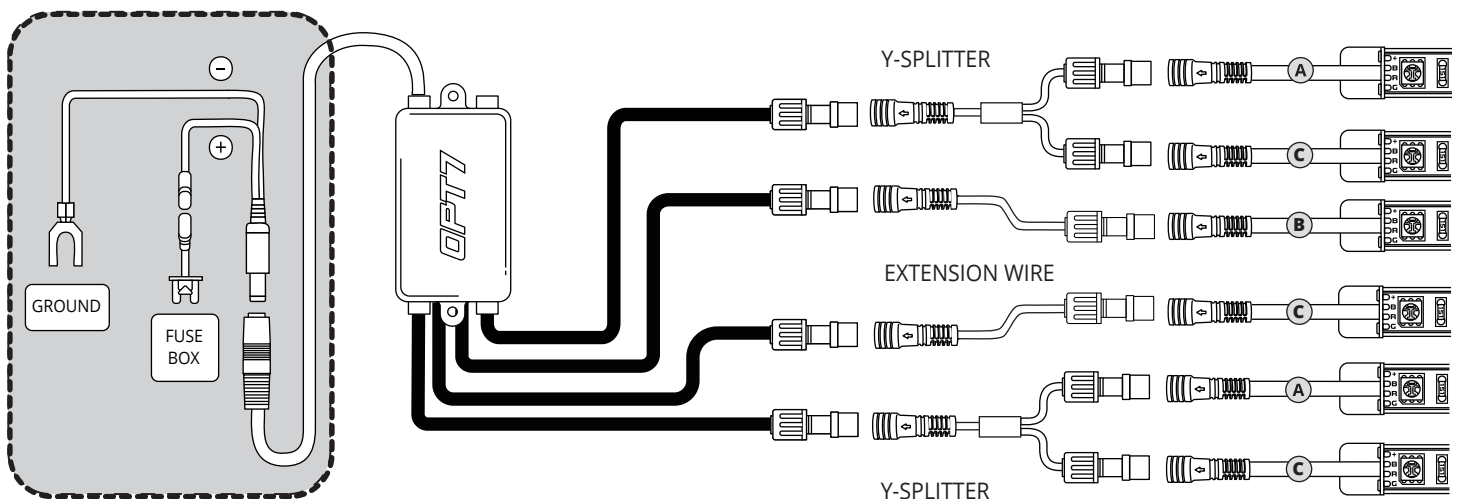

WARNING

1. Connecting to more than 10 AMP will override the kit and cause early failure, ensure it is 10 AMP or less !!
2. Please ensure the Underglow LED Bars / Control Box / Wirings are all mounted away from heated surfaces exceeding from 85°C or 185°F.

DISCLAIMER

OPT7 Lighting is not liable for damages or personal injuries while installing this product. The Installation Guide is intended as assistance to reduce setup time. OPT7 Lighting assumes no responsibility for improper installation. If you are unfamiliar with your vehicle or inexperienced with aftermarket upgrades, please seek professional assistance.

OPT7 recommends installation for safety and guidance.
Modified installations or installation recommendations not specified by OPT7 Lighting will void product warranty.