

AURATM

UNDERBODY WHITE

RV CLASS B/B+ FIT

INSTALLATION GUIDE

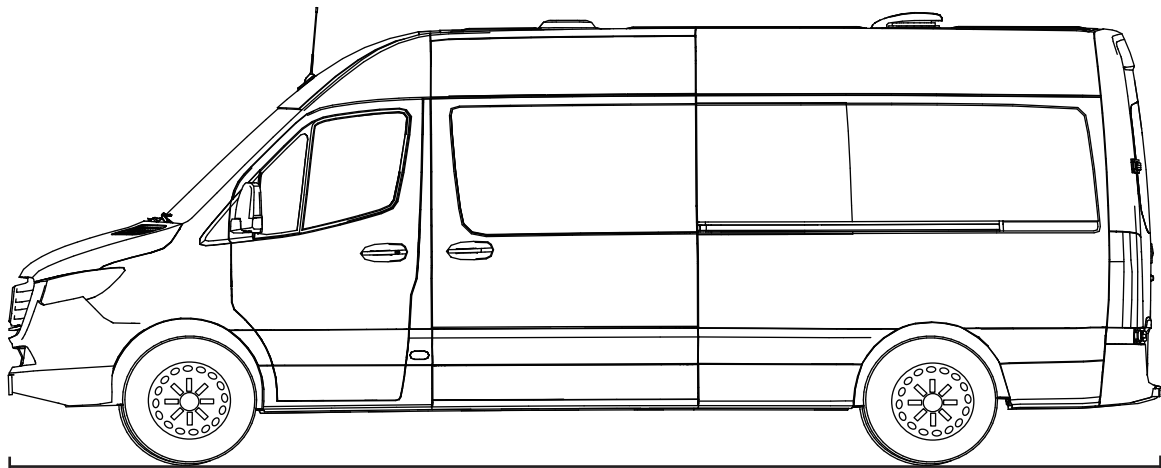

RV Class B : 19~23 ft
RV Class B+: 19~24 ft

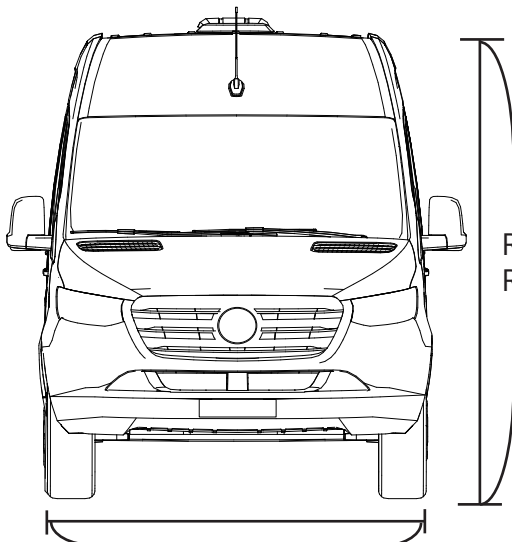

RV Class B : 10 ft
RV Class B+: 11 ft

RV Class B : 7 ft
RV Class B+: 8.1 ft

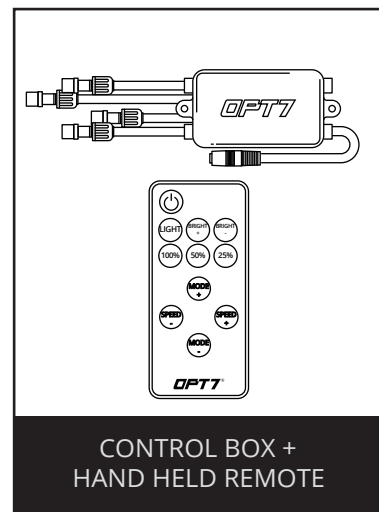

CONTROL BOX +
HAND HELD REMOTE

COMPONENTS

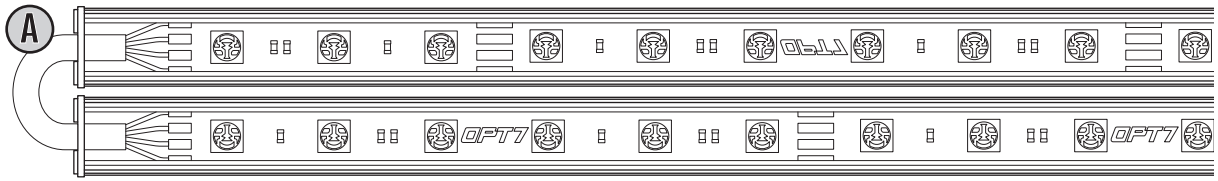

RIGID LIGHT BARS 2×48" (TWO-SECTION MOVABLE 24") + 8ft EXTENSION WIRE

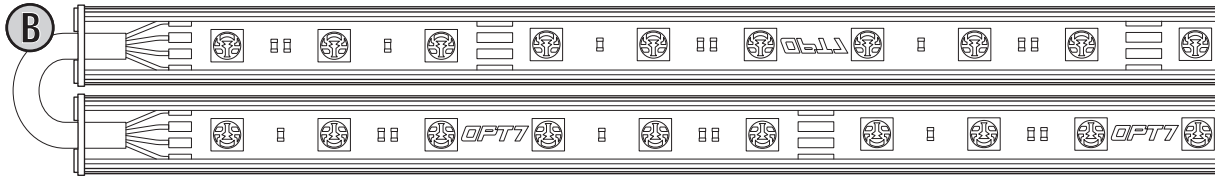

RIGID LIGHT BARS 1×36" (TWO-SECTION MOVABLE 18") + 8ft EXTENSION WIRE

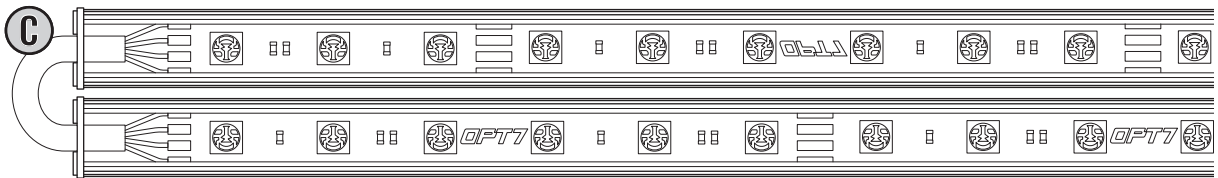

RIGID LIGHT BARS 3×36" (TWO-SECTION MOVABLE 18") + 18ft EXTENSION WIRE

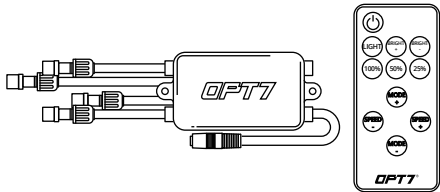

CONTROL BOX + HAND HELD REMOTE

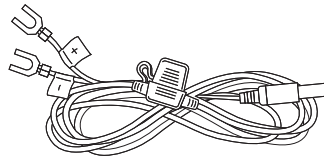

HARDWIRE POWER HARNESS

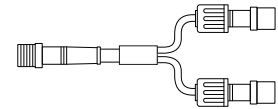

Y-SPLITTERS

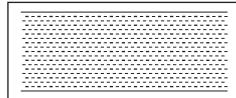
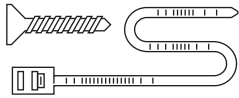

INCLUDES -
WIRE MOUNTS, SELF-TAPPING
SCREWS, BOOSTER, VELCRO, ZIP TIES

MOUNTING KIT

INSTALLATION

STEP 1

Inspect kit to ensure all contents were included.

STEP 2

Determine where to locate the control box and ensure wiring has enough length for light bars to be installed in desired location.

IMPORTANT

The control box must be installed inside the vehicle as it is not waterproof. **Avoid installation in areas of the engine bay + heated surfaces.**

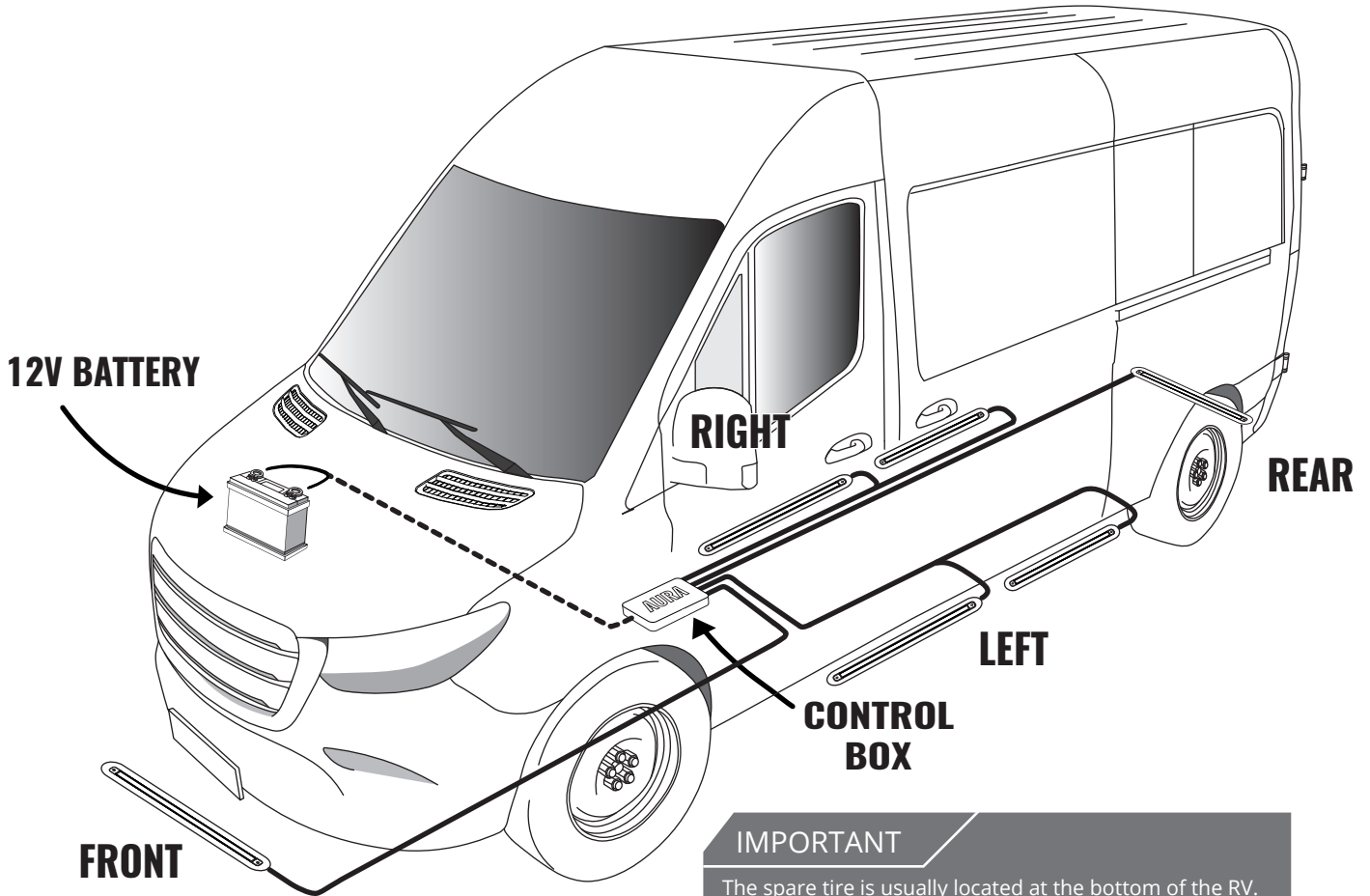

IMPORTANT

The spare tire is usually located at the bottom of the RV. Please pay attention to the position of the spare tire of your RV after installing the rear light bar. Please find a suitable place to install the rear light bars so the spare tire can be used normally.

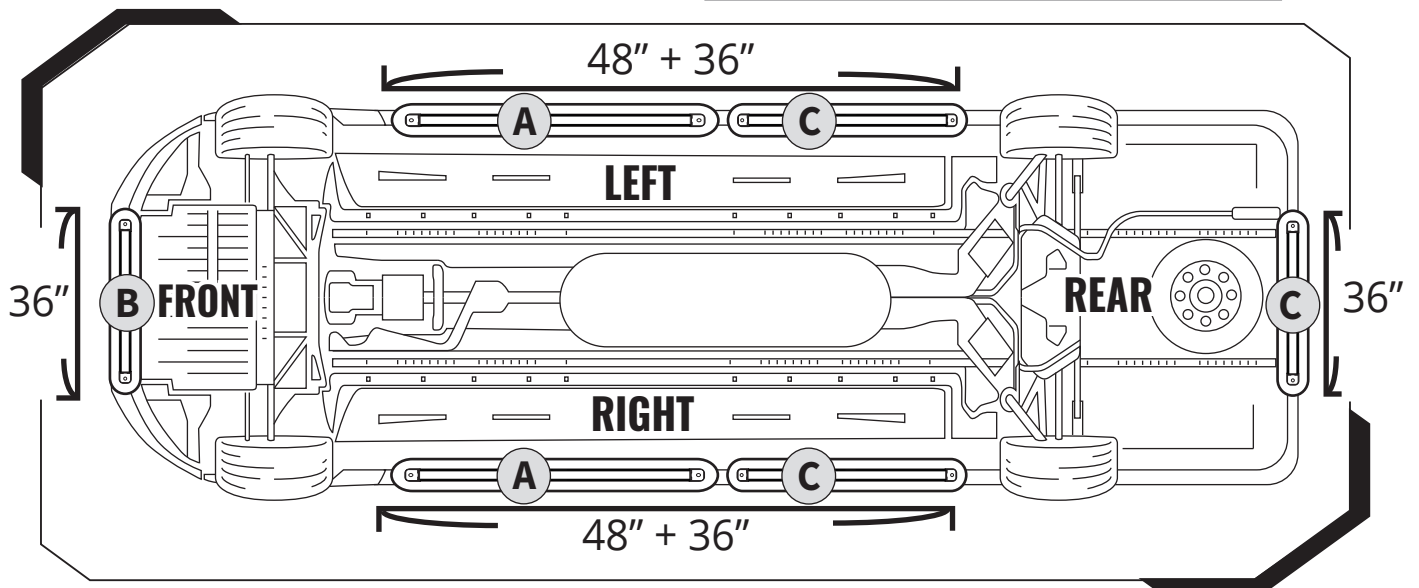

EXAMPLE

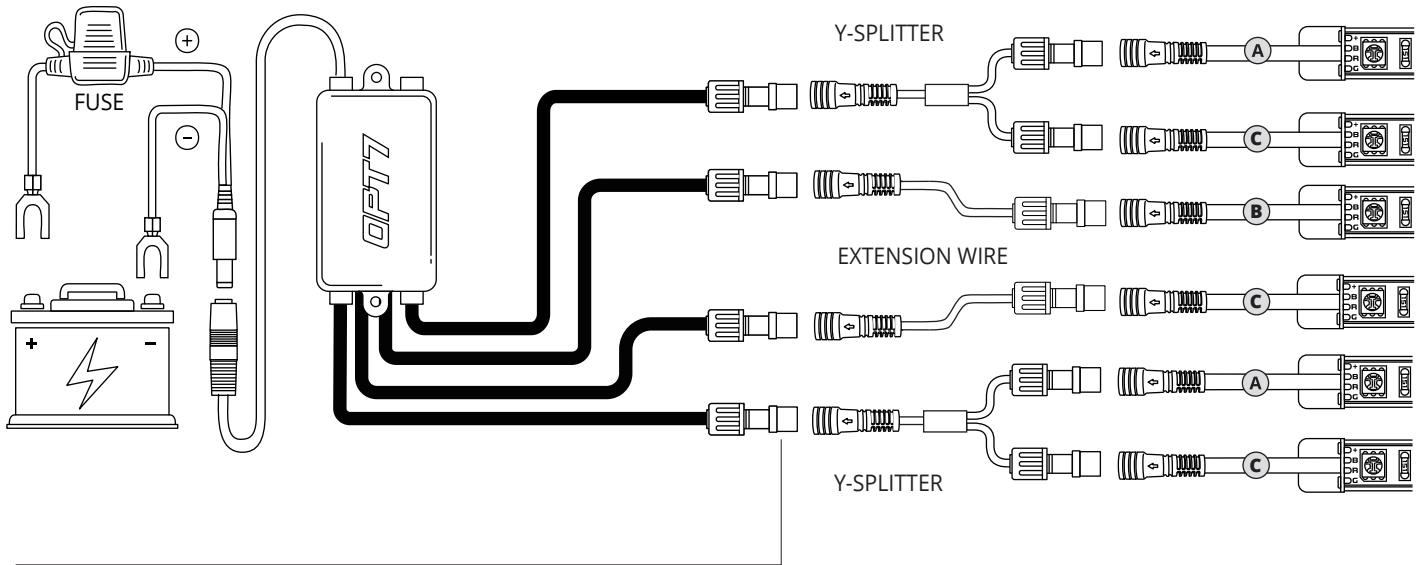

- (B)
- (A)
- (C)
- (A)
- (C)
- (C)

- 1 x 36" (two-section movable 18") LED Bar + 8ft extension wire
- 1 x 48" (two-section movable 24") LED Bar + 8ft extension wire +
- 1 x 36" (two-section movable 18") LED Bar + 18ft extension wire
- 1 x 48" (two-section movable 24") LED Bar + 8ft extension wire +
- 1 x 36" (two-section movable 18") LED Bar + 18ft extension wire
- 1 x 36" (two-section movable 18") LED Bar + 18ft extension wire

IMPORTANT:

The extension wires are on the LED bars. Lay out the bars to measure the length prior to install for a successful installation.

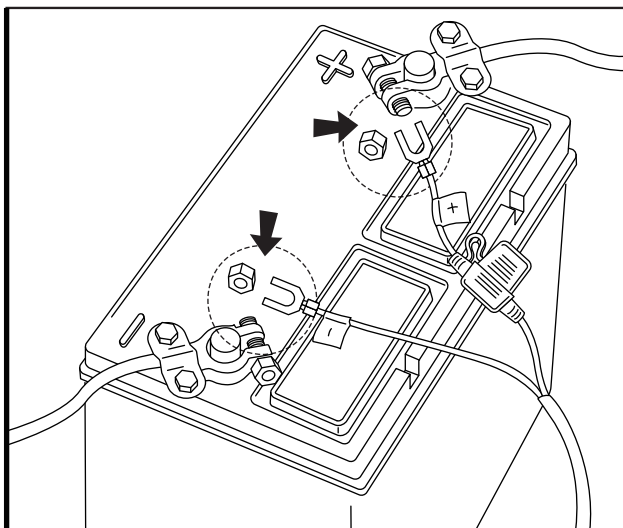

HOW TO CONNECT POWER HARNESS TO YOUR VEHICLE

- Connect the Red wire (+) of power harness to the vehicle battery's positive terminal.
- Connect the Black wire (-) of power harness to the vehicle battery's negative terminal or an unpainted area on your vehicle's frame.



WARNING

Please ensure the Underbody LED Bars / Control Box / Wirings are all mounted away from heated surfaces exceeding from 85°C or 185°F.

WARNING!

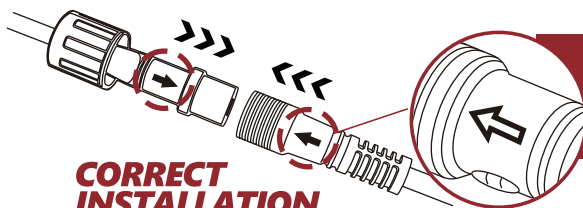

Note the direction of the arrows

CORRECT INSTALLATION

PRODUCT WARRANTY WILL BE VOID FOR IMPROPER INSTALL.

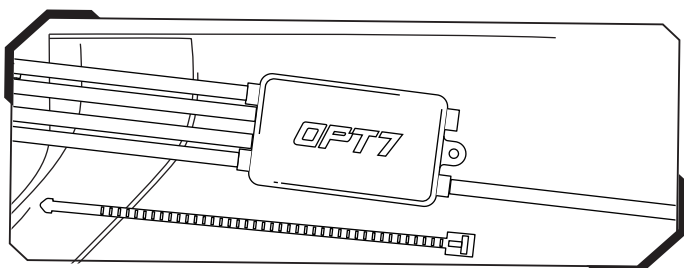

STEP 3

Secure control box in desired location with Velcro or zip ties.

*** CONTROL BOX NOT WATERPROOF**
Ensure the control box is safely and securely hidden from exposing elements of moisture.

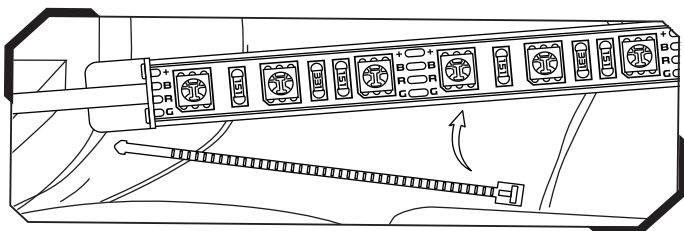

STEP 4

Secure the light bars using the zip ties to tie all the wiring away from the moving components.

STEP 5

Using the included E-Z Remote, select your desired mode, flashing speed, brightness.

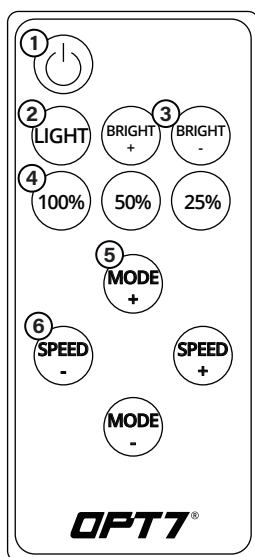

- 1 | Power-ON/OFF
- 2 | Switch **Dynamic** and **Static** modes
- 3 | Brightness +/- **11 Levels**
- 4 | Brightness 100%/50%/25%
- 5 | Mode +/- **10 Modes**
- 6 | Speed +/- **11 Levels**

IMPORTANT:

Pressing the BRIGHT +/- buttons in dynamic mode will switch to static mode.
Pressing the MODE +/- buttons in static mode will switch to dynamic mode.

NOTE: When you use this product, stay within 10m/33ft from the control box.

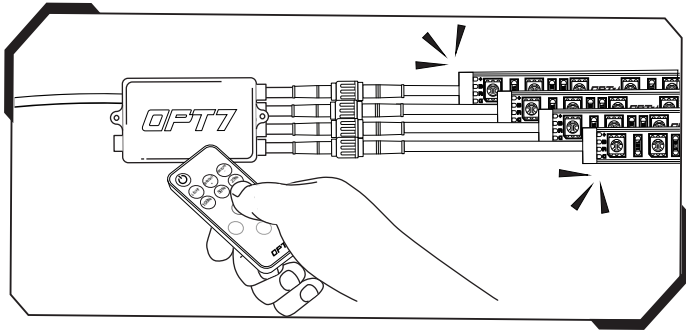

HOW TO PAIR THE REMOTE?

Pair the Device:

To pair the remote, reconnect the power, then aim the remote at the control box and hold the ON button until the LED bars flash white.

Unpair the Device:

To unpair the remote, reconnect the power, then aim the remote at the control box and hold the OFF button until the LED bars flash white.

OPTIONAL

To power the kit using a 10 AMP fuse tap method, you may purchase the AURA Universal Replacement Fuse Tap Adapter Set & Power Wire on our website. (*Not included; sold separately.)

Feel free to contact us using the link below for product inquires or installation support.

OPT7 SUPPORT TEAM: <https://www.opt-7.com/pages/customer-support>

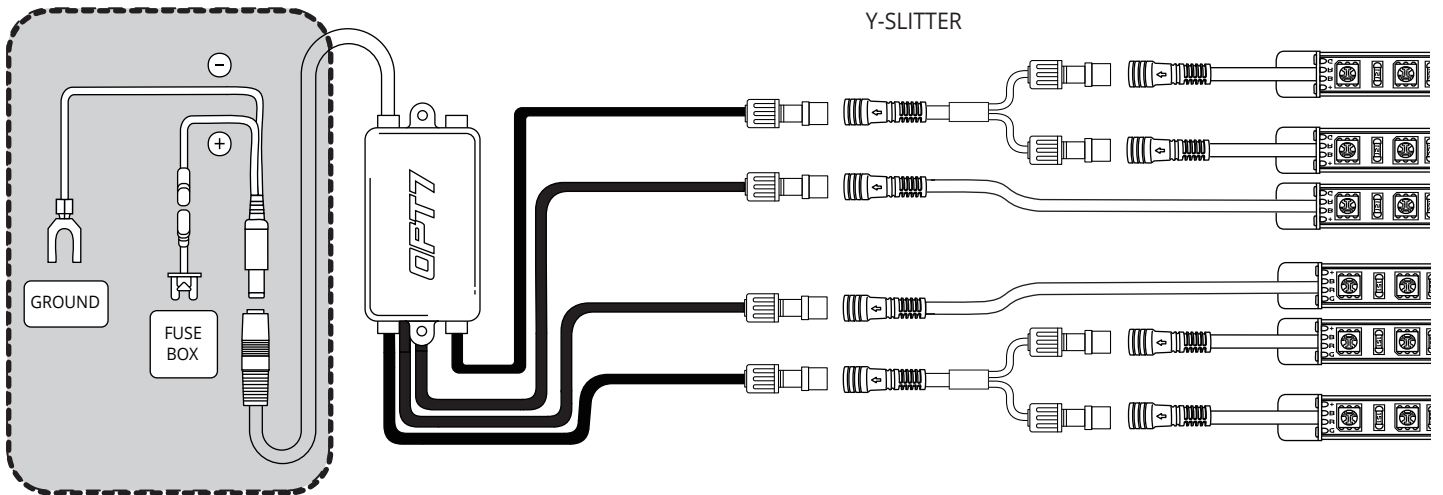

WARNING

1. Connecting to more than 10 AMP will override the kit and cause early failure, ensure it is 10 AMP or less !!
2. Please ensure the Underbody LED Bars / Control Box / Wirings are all mounted away from heated surfaces exceeding from 85C or 185F.

DISCLAIMER

OPT7 Lighting is not liable for damages or personal injuries while installing this product. The Installation Guide is intended as assistance to reduce setup time. OPT7 Lighting assumes no responsibility for improper installation. If you are unfamiliar with your vehicle or inexperienced with aftermarket upgrades, please seek professional assistance.

OPT7 recommends installation for safety and guidance.
Modified installations or installation recommendations not specified by OPT7 Lighting will void product warranty.