

REDLINE EASY CONNECT EXPANSION ADAPTER

FOR FORD MAVERICK
ECOBOOST 2022-2024

NO BLIS/BACKUP CAMERA/ASSIST SENSOR

Hello Fellow OPT7-ites, Introducing the Redline Quick Connect Harness to Flat
4-Pin Extension Adapter Harness

The OPT7 Redline Easy Connect Expansion Adapter Harness is purpose-built to be used as a trailer accessory for 2022-2024 Maverick **without Co-Pilot360 Technology Package or 2.5L Hybrid**. It provides a plug-and-play style that allows you to quickly, seamlessly and virtually hidden installation without cutting or splicing your factory harnesses.

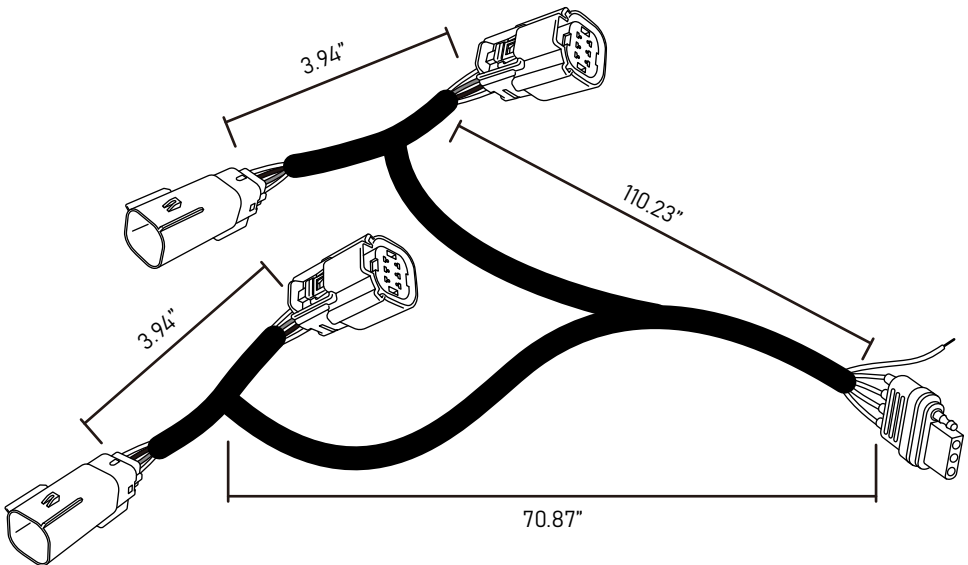

INSTALLATION

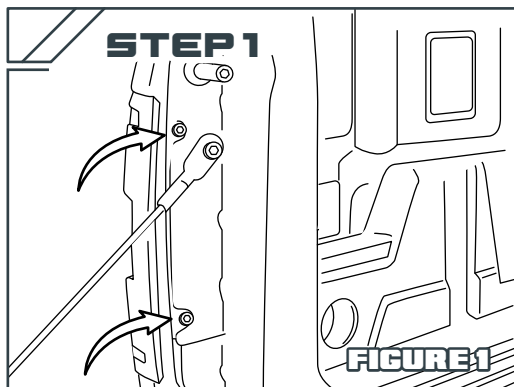

Open up your tailgate first.

Next, locate the two bolts that lock the tail light (See Figure 1) and loosen them.

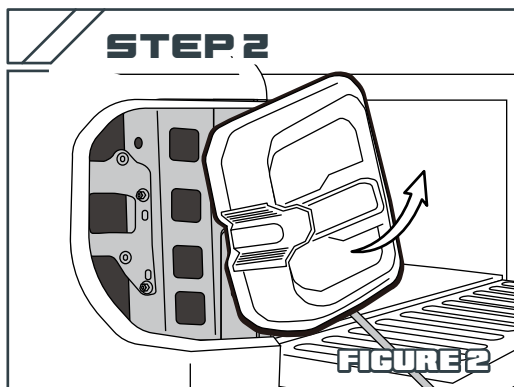

Slowly move the loose tail light until it is completely removed. (See Figure 2)

IMPORTANT

There are two plastic clips on the inside of the tail light for fixing, please be careful not to break it when removing it.

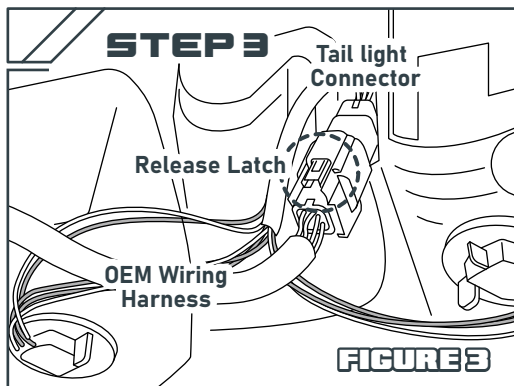

Locate the OEM wiring harness (See Figure 3) and unplug it from the tail light assembly by lightly pressing the Release-Latch on the connector.

HOW TO CONNECT PNP EXPANSION ADAPTER TO YOUR TAILLIGHTS

STEP 4

To make it easier for you to identify the signal location represented by the Connector /Wiring. Please read the relevant wiring instructions carefully before commencing any work.(See Figure 4)

OEM TAIL LIGHTS

RIGHT
Passenger Side

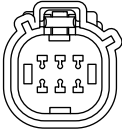

Tail light Connector

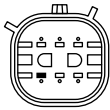

OEM Wiring Harness

LEFT
Driver's Side

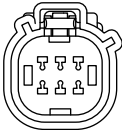

Tail light Connector



OEM Wiring Harness

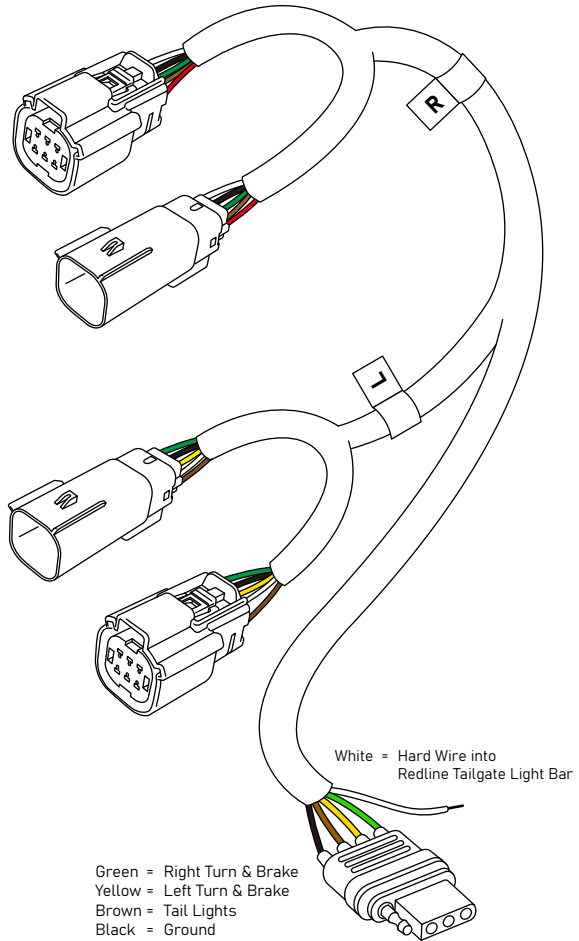
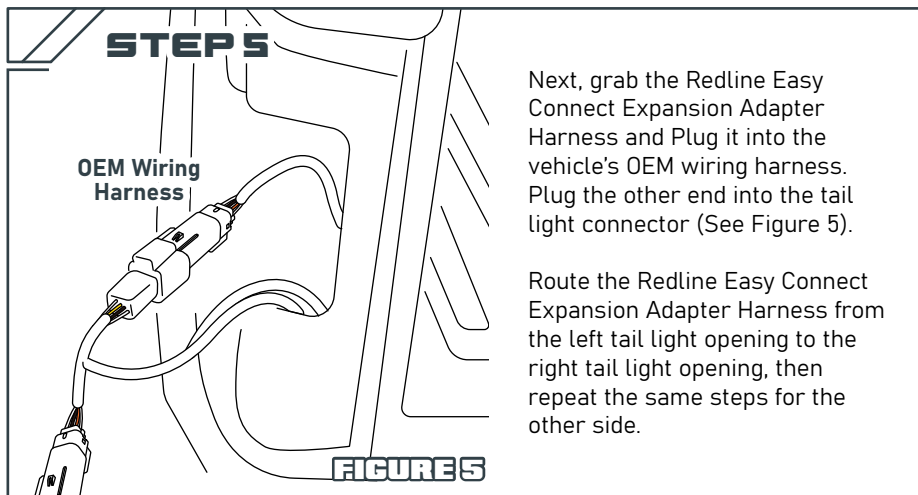

FIGURE 4

INSTALLATION



Next, grab the Redline Easy Connect Expansion Adapter Harness and Plug it into the vehicle's OEM wiring harness. Plug the other end into the tail light connector (See Figure 5).

Route the Redline Easy Connect Expansion Adapter Harness from the left tail light opening to the right tail light opening, then repeat the same steps for the other side.

STEP 6

Use some zip ties to secure the flat 4PIN trailer connector and reverse wire in place along the inner bumper.

STEP 7

Finally, connect the available tailgate light bar to the 4PIN trailer connector and reverse wire for full functionality testing

DISCLAIMER

OPT7 Lighting is not liable for damages or personal injuries while installing this product. The Installation Guide is intended as assistance to reduce setup time. OPT7 Lighting assumes no responsibility for improper installation. If you are unfamiliar with your vehicle or inexperienced with aftermarket upgrades, please seek professional assistance.

OPT7 recommends installation for safety and guidance.

Modified installations or installation recommendations not specified by OPT7 Lighting will void product warranty.