

OPT7

EASY CONNECT

7 Pin & 4 Pin Circuit Tester Adapter

Combines a 4-way circuit tester and 7-way trailer light tester, while also converting 7-pin output for connecting 4-way trailer plugs, suitable for most trucks.

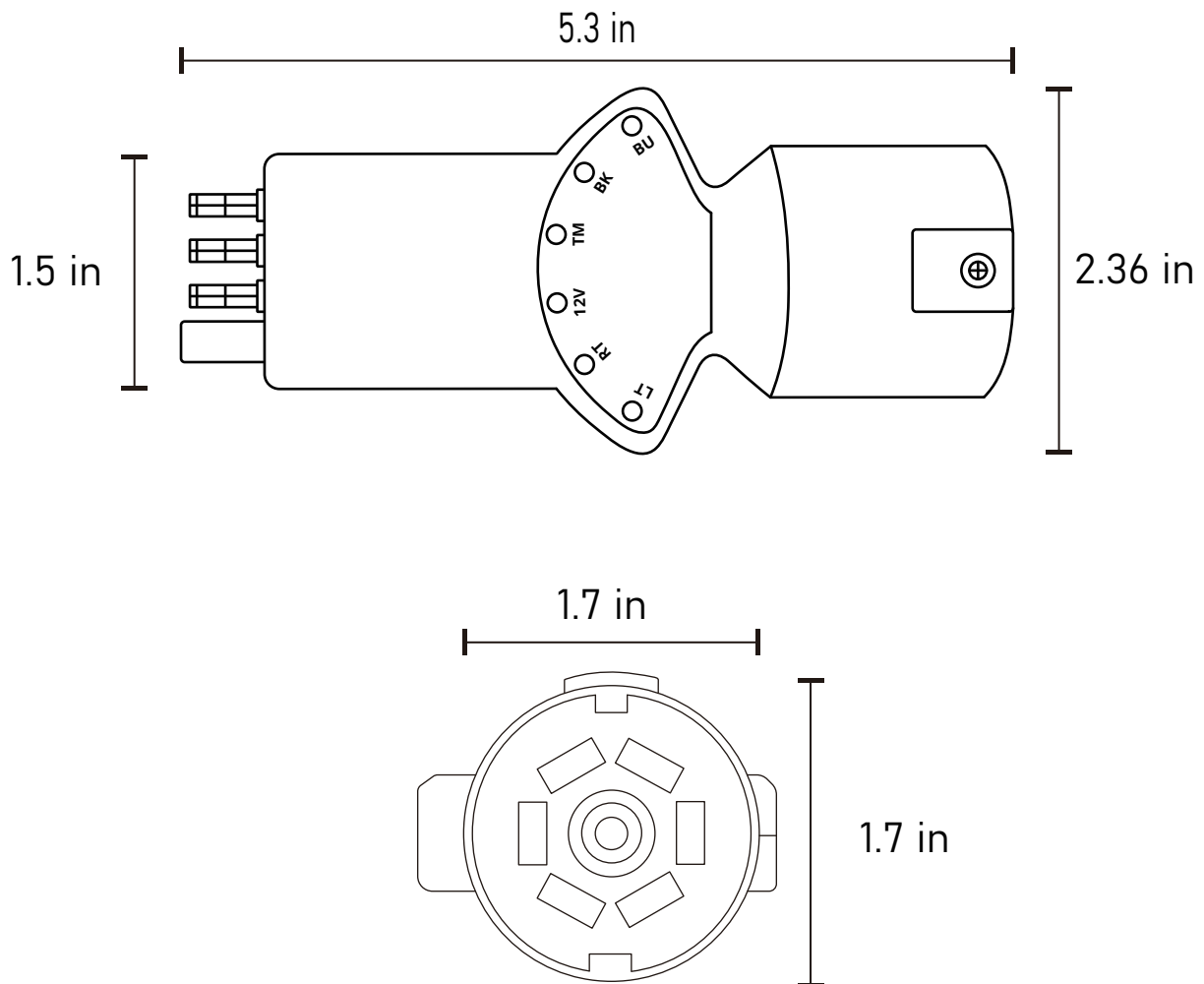

OPT7[®]

INSTALLATION

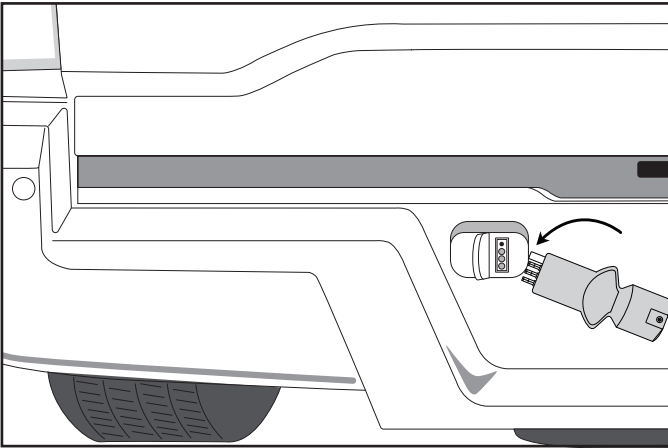

Plug the 4-pin flat connector into the proper receptacle on the vehicle.

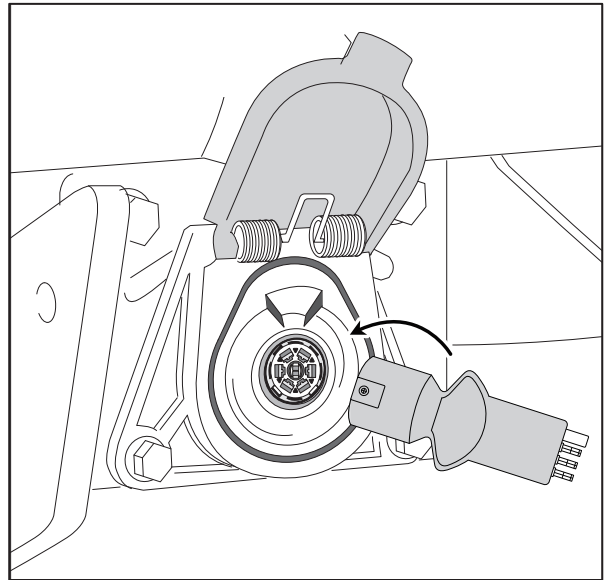

Open the trailer wiring hatch located near the rear bumper.
Plug the 7-pin flat connector into the proper receptacle on the vehicle.



NOTE

*The trailer tester will be upside down when testing for 2017+ newer Ford/Chevy/G-MC models.

*Can't test LED lighting system. Doesn't work with vehicle has lamp-out sensor, such as BMW, VW, Mercedes-Benz, Porsche, etc.

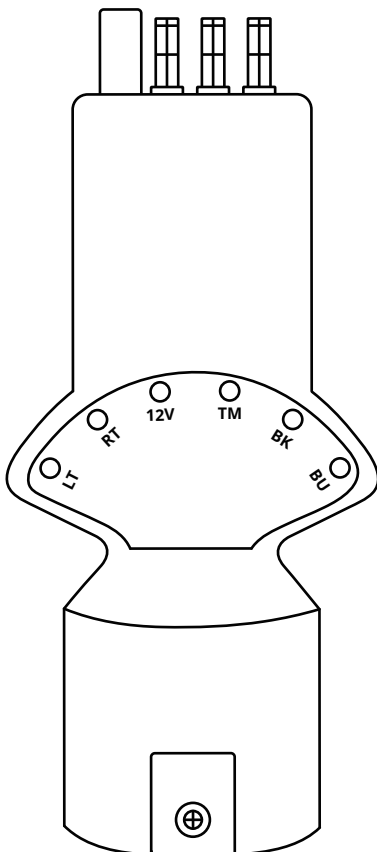

6 LIGHT FUNCTIONS

LT	Left turn / Stop
RT	Right turn / Stop
12V	Auxiliary power(12V+)
TM	Tail lights
BK	Electric brakes
BU	Backup / Reverse

DISCLAIMER

OPT7 Lighting is not liable for damages, injuries, or death while installing this product. The Installation Guide is intended as assistance to reduce setup time. OPT7 Lighting assumes no responsibility for improper installation. If you are unfamiliar with your vehicle or inexperienced with aftermarket upgrades, please seek professional assistance.