

# AURA™

# UNDERBODY

— WITH DOOR ASSIST/8PC —

## INSTALLATION GUIDE

### MAIN COMPONENTS

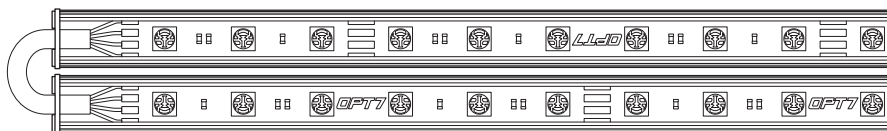

RIGID LIGHT BARS 18"×4 + 24"×4



AURA CONTROL BOX

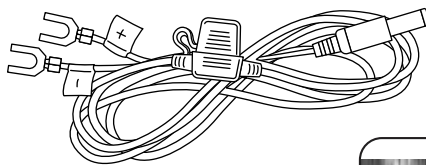

HARDWIRE POWER HARNESS

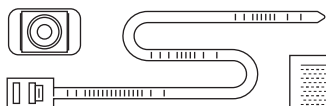

MOUNTING KIT

INCLUDES -  
WIRE MOUNTS, SELF-TAPPING SCREWS, BOOSTER, VELCRO, ZIP TIES

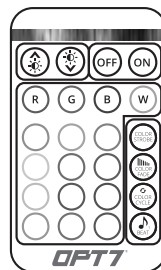
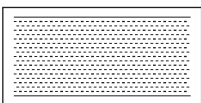

HAND  
HELD REMOTE

# INSTALLATION

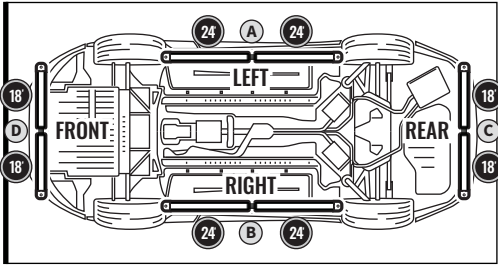

## STEP 1

Decide where to locate the control box and ensure wiring has enough length for light bars to be installed in desired location.

### IMPORTANT:

The control box must be installed inside the vehicle as it is not waterproof. **Avoid installation areas of the engine bay + heated surfaces.**

As shown below, connect all the LED bars to the control box with the included extension cables.

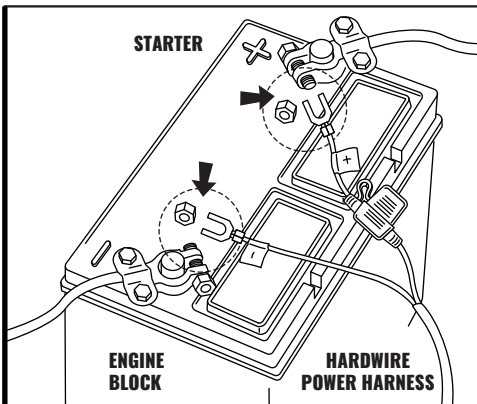
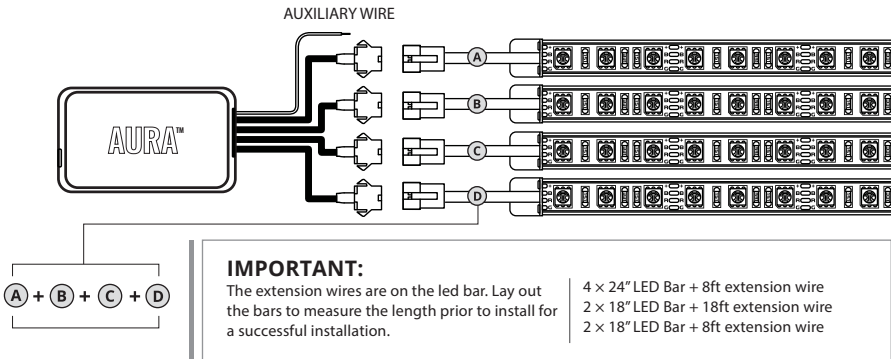

## HOW TO CONNECT POWER HARNESS TO YOUR VEHICLE

- Connect the Red line(+) of power harness to the vehicle battery's positive terminal.
- Connect the Black line (-) of power harness to the vehicle battery's negative terminal or an unpainted area on your vehicle's frame.



**WARNING**

1. Connecting to more than 10 AMP will override the kit and cause early failure, ensure it is 10AMPs or less!!
2. Please ensure that the LED bars or strips/control box/wiring all are mounted in areas where will not exceed 85°C or 185°F.

# INSTALLATION

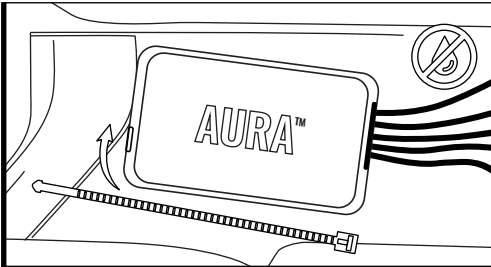

## STEP 2

Secure Control box in desired location with Velcro or zip ties.

**\* CONTROL BOX NOT WATERPROOF**  
Ensure the control box is safely and securely hidden from exposing elements of moisture.

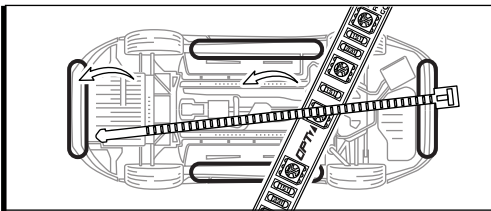

## STEP 3

Secure the light bars using the zip ties to tie all the wiring away from the moving components.

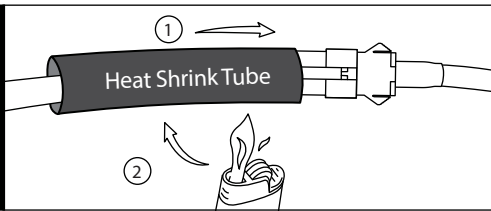

**\* IMPORTANT:**

The LED connectors are not waterproof. You will need to use HEAT SHRINK TUBE (not included) or ELECTRICAL TAPE around the LED connectors to ensure the longevity of the lighting kit.

**STEP 4** Using the included E-Z Remote, select your desired color or pattern.

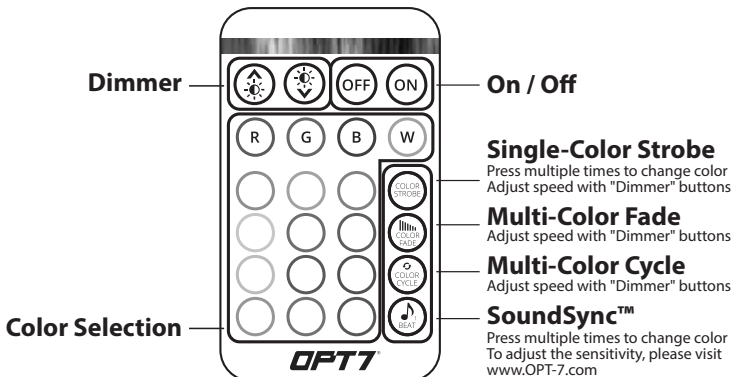

# | AUX WIRING FOR A DOOR/DOME LIGHT



Please scan to see a detail instruction on Door Assist Sync or go to <https://wintis.ladesk.com/549690-AURA-Door-AssistAUX-Installation-Guide>

## | OPTIONAL UPGRADE

Upgrade your Aura Original Control Box to the Aura Pro Bluetooth Control Box.  
All new AURA Pro Bluetooth is App enabled by a smartphone controller (iOS & Android Compatible).

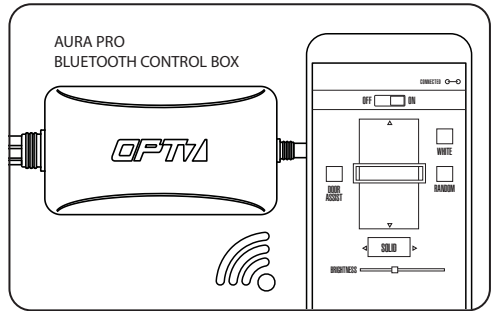

## | DISCLAIMER

OPT7 Lighting is not liable for damages or personal injuries while installing this product. The Installation Guide is intended as assistance to reduce setup time. OPT7 Lighting assumes no responsibility for improper installation.  
If you are unfamiliar with your vehicle or inexperienced with aftermarket upgrades, please seek professional assistance.

OPT7 recommends installation for safety and guidance.

Modified installations or installation recommendations not specified by OPT7 Lighting will void product warranty.